

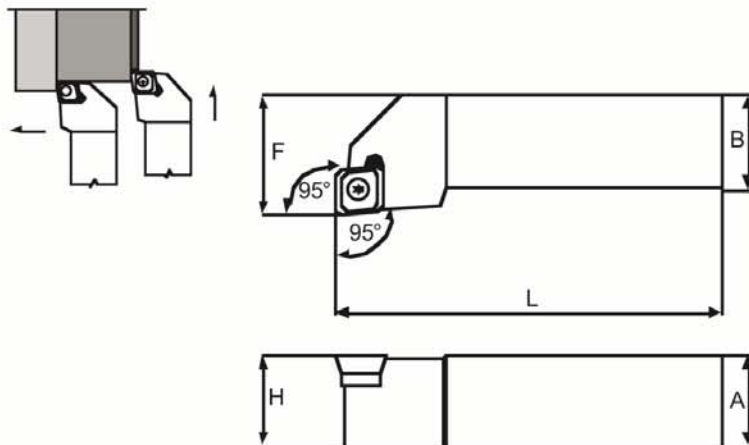



External turning tools  
 Outils de tournage extérieur  
 Werkzeuge für Aussenbearbeitung

# SCLCR/L

Utensili per tornitura esterna

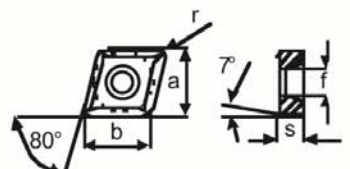

Codice	Dimensioni mm					Inserto	Parti di Ricambio			
	F	H	B	A	L					
SCLCR/L 0808 D 06	10	8	8	8	60	CCMT06			TX2506	BTX08
SCLCR/L 1010 E 06	12	10	10	10	70	CCMT06			TX2506	BTX08
SCLCR/L 1212 F 09	16	12	12	12	80	CCMT09			TX3509	BTX15
SCLCR/L 1616 H 09	20	16	16	16	100	CCMT09	BSCL09	BU4560	TX3509	BTX15
SCLCR/L 2020 K 09	25	20	20	20	125	CCMT09			TX3509	BTX15
SCLCR/L 2020 K 12	25	20	20	20	125	CCMT12	S8012P	BO609	TX4014	BTX15
SCLCR/L 2525 M 12	32	25	25	25	150	CCMT12	S8012P	BO609	TX4014	BTX15
Inserto	a	b	s	r						
CCMT0602	6.35	6.45	2.38	0.4						
CCMT09T3	9.52	9.65	3.97	0.4						
CCMT1204	12.7	12.9	4.76	0.8						