

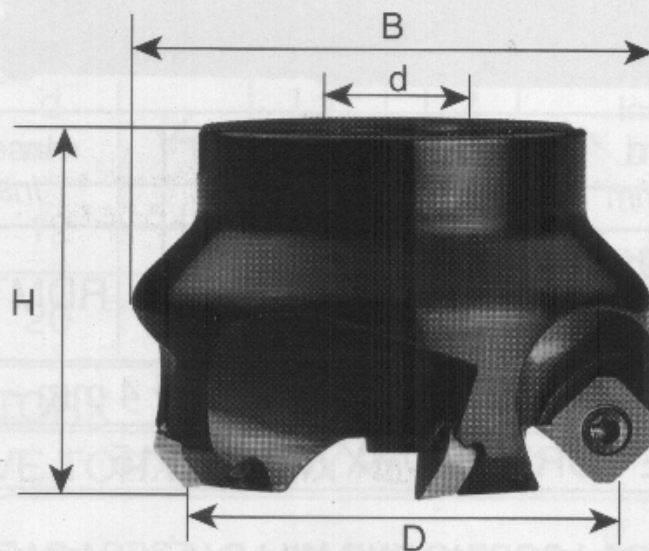

FRESA A INSERTO A 45° - FACE MILLING CUTTER 45°
FRESA CON PLAQUITA 45°



CODICE CODE	D mm	H mm	B mm	d mm	Z	Inserto Insert	
F303 / 040	40	45	53	16	3	SEHX 1204	T20/50 KV 500
F303 / 050	50	48	60	22	4		
F303 / 063	63	50	76	22	5		
F303 / 080	80	50	93	27	5		
F303 / 100	100	50	113	32	6		
F303 / 125	125	60	138	40	7		
KV500	VITE TORX - TORX SCREW Ø 5 mm - 10 Pz / Pcs						
0881/10020	CHIAVE TORX - TORX KEY T20						

Inserti non compresi / Inserts not included / Plaquitas no incluidas